



TOA 288

Fuel Efficient & Compact Engine

Capable to operate under harsh environmental conditions

Suitable for pusher and tractor applications

Horizontal or vertical installation



www.suter-aviation.ch
www.suter-industries.ch

SUTER INDUSTRIES AG
Head-Quarter

Mr. Lars Jäger
Mettlenstrasse 3
CH-8488 Turbenthal
Phone: +41 52 397 10 60
Mail: info@suter-industries.ch

CAE GmbH
For International

Mr. Dietrich Kehe
Maria Jacobi Gasse 1
A-1030 Vienna
Phone: +49 172 900 2619
Mail: info@cae-engines.com

UAV PROPULSION TECH
Representative for USA

Mr. Bob Schmidt
US-33606 Tampa (FL)
Phone: +1(810)441-1457
Mail: bob@uavpropulsiontech.com

Technical Data

Altitude	20'000 ft
Performance	17,6 kW at 6'500 rpm 27,2 Nm at 6'000 rpm
Fuel Efficiency	315 g/kW/h BSFC (Best Specific Fuel Consumption)
Displacement	288 cm ³
Weight	9,2 kg engine 2,0 kg exhaust & silence 1,1 kg 1 kw / 28V regulator
Management & Control	ECU / 12V-system Automatic via ECU
Ignition System	CDI (Capacitor Discharge Ignition)
Fuel	Gasoline, 1,6 % synthetic oil

Technical Features

- Two-cylinder, two-stroke boxer engine
- ▶ horizontal & vertical Installation
 - ▶ crankshaft in high strength steel, single piece connecting rods with needle bearings
 - ▶ Cylinders in casted aluminium, nickel-silicone coated barrel
 - ▶ Throttle control by SERVO, controlled via ECU
 - ▶ ECU for fuel, ignition, cold start, EGT, CHT, altitude compensation, overheat protection

Options

- ▶ Oil injection
- ▶ 1kW/28VDC Starter Generator Central Unit
- ▶ 500W/28VDC General Centre Unit
- ▶ Double ignition
- ▶ Reduction drive

Dimensions

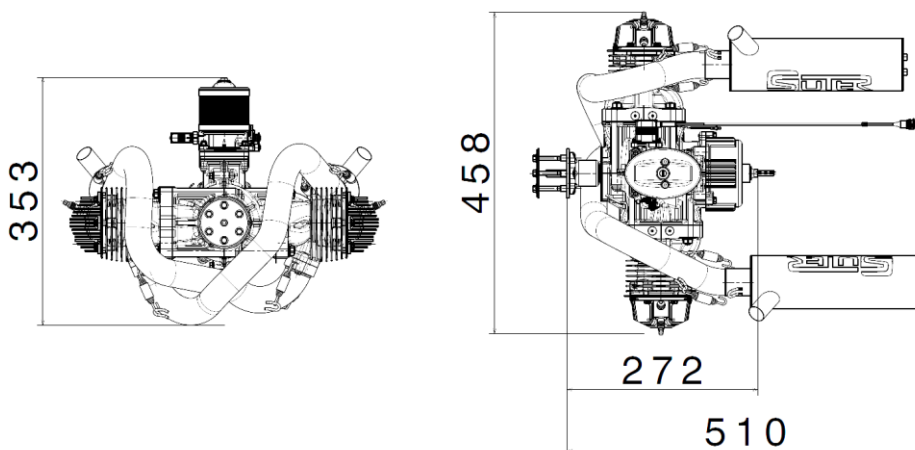

Performance Curve

